

REVISIONS						
ECN	REV.	DESCRIPTION	DATE	DRAW	CHECK	APPROVED
	A	Initial Release	2009/03/13	XY	XY	XY
954	B	ADD PAGE5	2011/03/11	XY	XY	XY

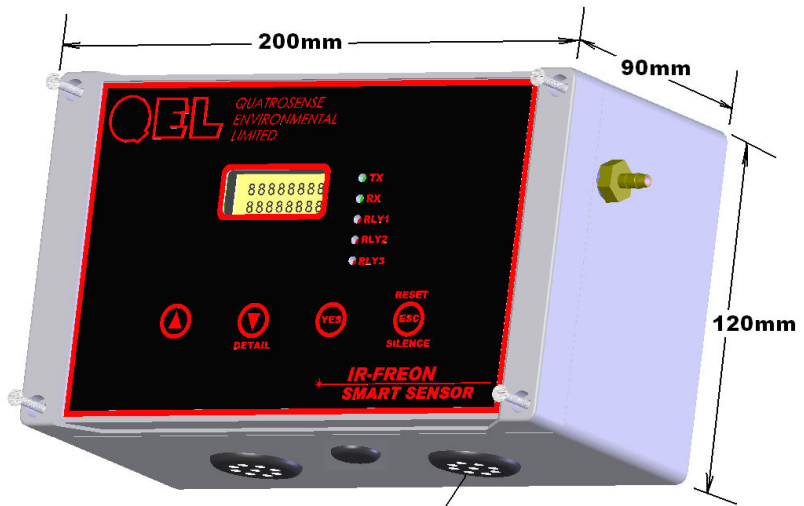

CAUTION:
SENSOR OPENING MUST BE PROTECTED
IN HEAVY WASHDOWN SITUATION

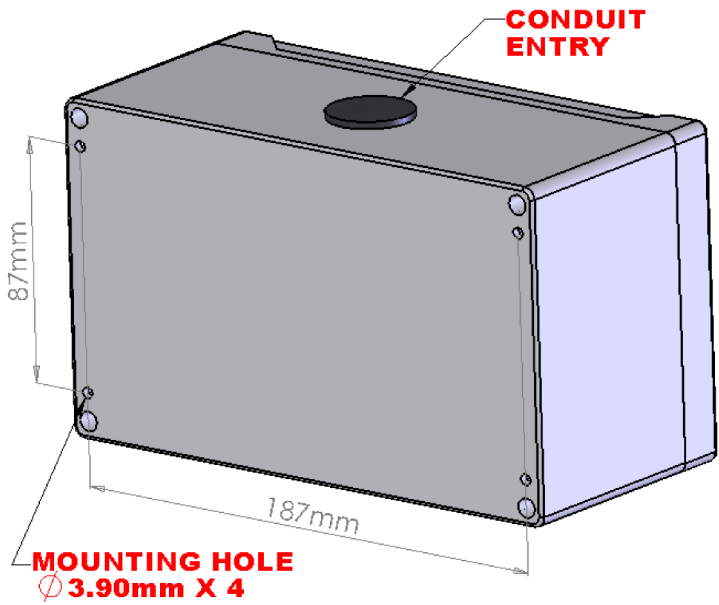

SPECIFICATION

INPUT POWER:
+24VDC nominal, range: 18 to 30VDC 1.0A DC Total Max.
~24VAC nominal, range: 15 to 24VAC 50/60HZ 1.0A AC Total Max.
(AC must not be grounded)

FUSE:
F1 on Display Board: Polyswitch 1.6A
F2 on Display Board: Polyswitch 50mA
Polyswitch device resets after the fault is cleared and power to the circuit is removed

SENSOR:
INFRARED FREON

OUTPUT SIGNAL:
RS-485 with OPTIMUX PROTOCOL AND MODBUS PROTOCOL
AVAILABLE CONTROLLER: M-CONTROLLER or Q4 CONTROLLER
4-20mA Analog Output
3X SPDT RELAYS: 1.0A MAX. @30VDC (RESISTIVE LOAD)
0.3A MAX. @125VAC (RESISTIVE LOAD)

ENCLOSURE:
IP 66 & NEMA 4, 4X, 12 & 13
COVER SCREWS SHOULD BE TORQUED TO 2.5 lbs-in (30 cN-m)

OPERATING TEMPERATURE:
-45 °C TO 65 °C

AMBIENT HUMIDITY:
5% TO 95% RH (NON- CONDENSING)

STORAGE TEMPERATURE:
-45 °C TO 70 °C

SIZE:
200mm X 120mm X 90mm

WEIGHT:
LESS THAN 1.5lbs (0.680 kg)

PROPRIETARY AND CONFIDENTIAL
THE INFORMATION CONTAINED IN THIS DRAWING IS THE SOLE PROPERTY OF Quatrosense Environmental Ltd. ANY REPRODUCTION IN PART OR AS A WHOLE WITHOUT THE WRITTEN PERMISSION OF Quatrosense Environmental Ltd. IS PROHIBITED.

		UNLESS OTHERWISE SPECIFIED:		NAME		DATE		Quatrosense Environmental Ltd	
		DIMENSIONS ARE IN INCHES		DRAWN		XY		2009/03/13	
		TOLERANCES:		CHECKED		XY		2009/03/13	
		FRACTIONAL: ± 1/32		ENG APPR.		XY		2009/03/13	
		ANGULAR:		MFG APPR.					
		MACH ± .5 degrees BEND ±		Q.A.					
		TWO PLACE DECIMAL ± .02		COMMENTS:					
		THREE PLACE DECIMAL ± .010							
		INTERPRET GEOMETRIC TOLERANCING PER:							
		MATERIAL							
		FINISH							
NEXT ASSY		USED ON							
APPLICATION		DO NOT SCALE DRAWING							
				TITLE:					
				IR-FREON-D					
				INSTALLATION DRAWING					
		SIZE		DWG. NO.		REV			
		B		85050-202-000		B			
		SCALE: 1:2		WEIGHT:		SHEET 1 OF 5			

Power and RS-485 Connection:

REVISIONS				
ZONE	REV.	DESCRIPTION	DATE	APPROVED
-	-	See Sheet1	-	-

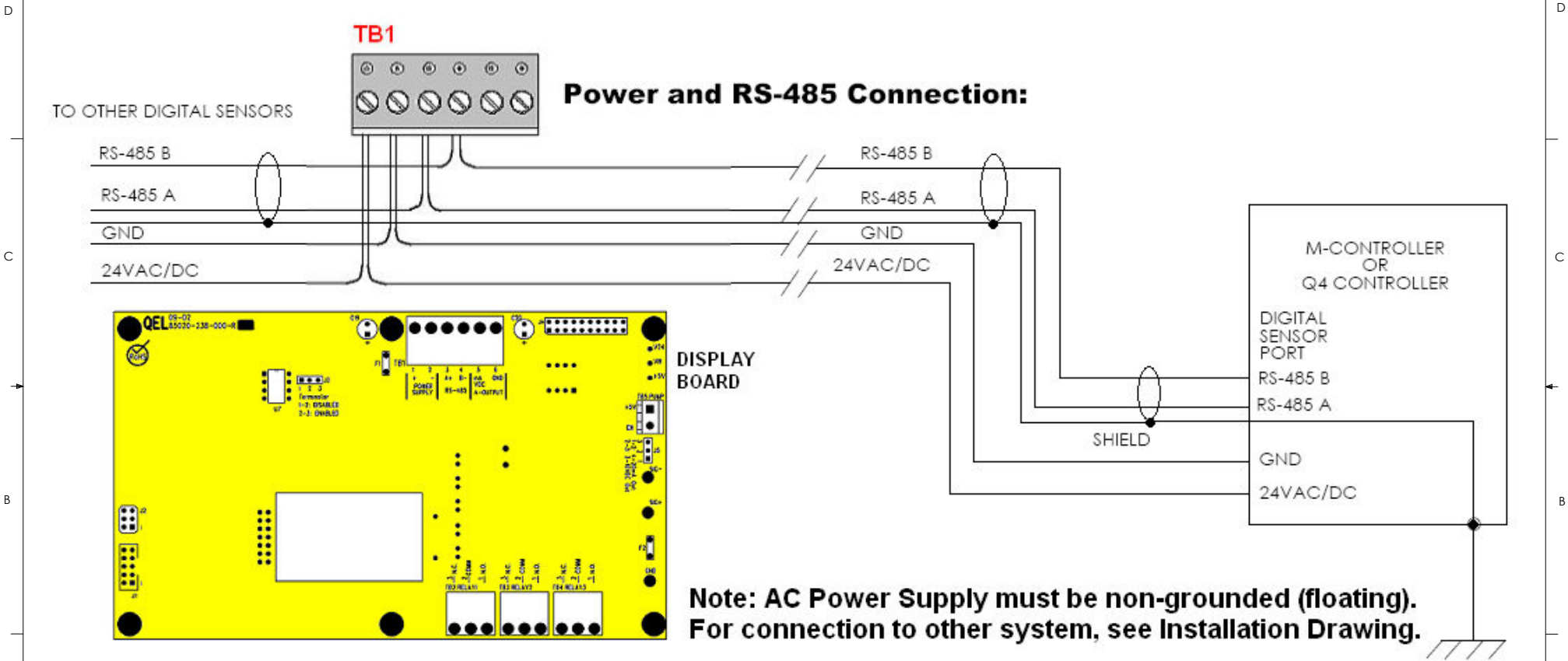

Note: AC Power Supply must be non-grounded (floating). For connection to other system, see Installation Drawing.

- NOTE:**
- GROUND THE SHIELD IN CONTROLLER SIDE
 - GROUND ON ONE END ONLY

PROPRIETARY AND CONFIDENTIAL
 THE INFORMATION CONTAINED IN THIS DRAWING IS THE SOLE PROPERTY OF <INSERT COMPANY NAME HERE>. ANY REPRODUCTION IN PART OR AS A WHOLE WITHOUT THE WRITTEN PERMISSION OF <INSERT COMPANY NAME HERE> IS PROHIBITED.

		UNLESS OTHERWISE SPECIFIED:		NAME		DATE		Quatrosense Environmental Ltd	
		DIMENSIONS ARE IN INCHES		DRAWN		XY		2009/03/13	
		TOLERANCES:		CHECKED		XY		2009/03/13	
		FRACTIONAL: ±		ENG APPR.		XY		2009/03/13	
		ANGULAR: MACH ± BEND ±		MFG APPR.					
		TWO PLACE DECIMAL ±		Q.A.					
		THREE PLACE DECIMAL ±		COMMENTS:					
		INTERPRET GEOMETRIC TOLERANCING PER:						TITLE:	
		MATERIAL						IR FREON-D	
		FINISH						INSTALLATION DRAWING	
NEXT ASSY		USED ON						SIZE	
								DWG. NO.	
								85050-202-000	
								REV	
								B	
APPLICATION		DO NOT SCALE DRAWING						SCALE: 1:2	
								SHEET 2 OF 5	

8 7 6 5 4 3 2 1

REVISIONS				
ZONE	REV.	DESCRIPTION	DATE	APPROVED
-	-	See Sheet1	-	-

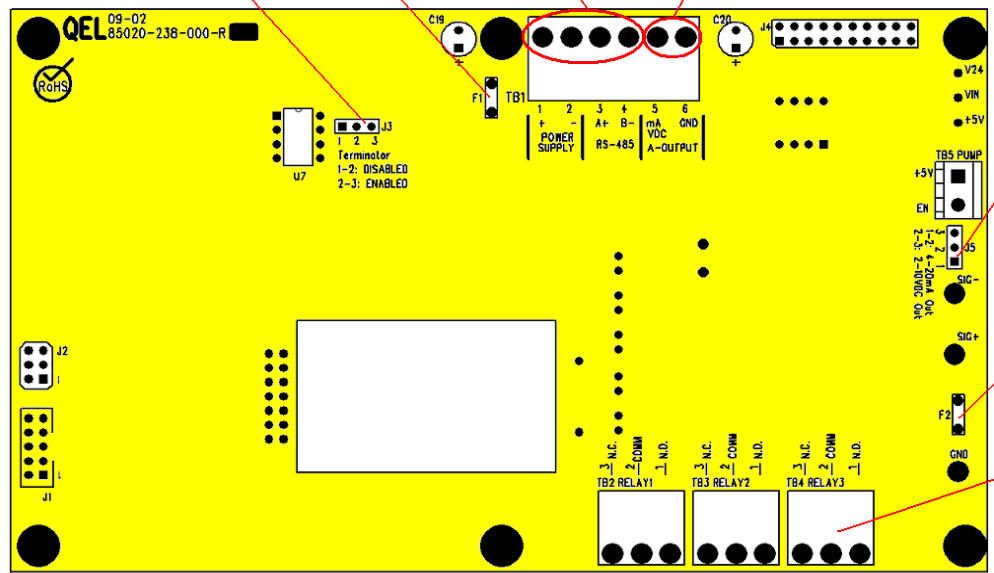

J5: Jumper
for TB1 5/6 pin
Output
1-2: 4-20mA
2-3: 2-10VDC

F2: Fuse
50mA

Relay1-3
Outputs

Terminator Enable/Disable?

The terminator on each end of the RS485 loop is designed to match the electrical impedance characteristic of the twisted pair loop, and will prevent signal echoes from corrupting the data on the line. The terminator should be enabled on BOTH ends of the RS485 loop. Short and medium length modbus/485 loops can operate without the terminating resistor. Longer runs may require the terminating resistors. But adding terminator dramatically increases power consumption.

Twisted Pair?

RS-485 is designed to be a balanced system. The signal on one wire is ideally the exact opposite of the signal on the second wire. In other words, if one wire is transmitting a high, the other wire will be transmitting a low, and vice versa. Although RS-485 can be successfully transmitted using multiple types of media, it should be used with wiring commonly called "twisted pair."

Sensor Location:

Several factors should be considered when selecting locations to install sensors. The following general suggestions should be considered to assure the detection of the target gas. Select the most suitable location for each sensor.

- Air Currents:** If there are fans, winds, or others sources of air movement, gases may tend to rise to collect in certain areas of a facility. The local air currents should be assessed to aid in selecting the sensor location. In outdoor situations considerations such as prevailing winds should be accounted for. Air convection can often be more important in determining gas concentrated areas than factors of Vapor Density.
- Vapor Density:** R11, R22, R123 and R134a are heavier than air. Detecting location should be 9 - 18 inch (0.23m to 0.46m) above the floor.
- Gas Emission Sources:** As a rule, at least one sensor should be located in close proximity to each point where a leak is likely to occur. This is particularly important when a liquid having a low volatility is monitored.
- Environmental Factors:** Designed to rugged outdoor use consider the following in selecting locations. Install sensors where they will be protected from wind, dust, snow, water, vibration and shock.

PROPRIETARY AND CONFIDENTIAL
THE INFORMATION CONTAINED IN THIS DRAWING IS THE SOLE PROPERTY OF <INSERT COMPANY NAME HERE>. ANY REPRODUCTION IN PART OR AS A WHOLE WITHOUT THE WRITTEN PERMISSION OF <INSERT COMPANY NAME HERE> IS PROHIBITED.

		UNLESS OTHERWISE SPECIFIED:		NAME		DATE		Quatrosense Environmental Ltd	
		DIMENSIONS ARE IN INCHES		DRAWN		XY		2009/03/13	
		TOLERANCES:		CHECKED		XY		2009/03/13	
		FRACTIONAL: ±		ENG APPR.		XY		2009/03/13	
		ANGULAR: MACH ± BEND ±		MFG APPR.					
		TWO PLACE DECIMAL ±		Q.A.					
		THREE PLACE DECIMAL ±		COMMENTS:					
		INTERPRET GEOMETRIC TOLERANCING PER:							
		MATERIAL							
		FINISH							
NEXT ASSY		USED ON							
APPLICATION		DO NOT SCALE DRAWING							
				TITLE:		IR FREON-D		INSTALLATION DRAWING	
		SIZE		DWG. NO.		REV			
		B		85050-202-000		B			
		SCALE: 1:2				SHEET 3 OF 5			

8 7 6 5 4 3 2 1

4-20mA Output:

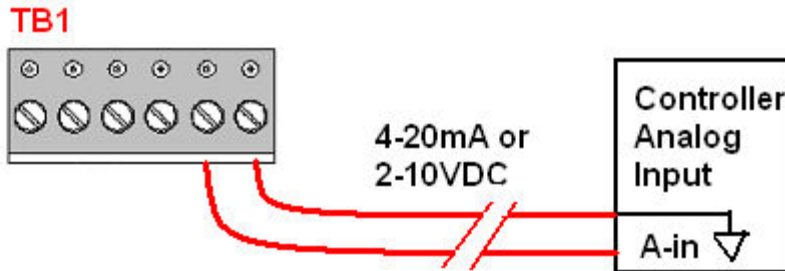

REVISIONS				
ZONE	REV.	DESCRIPTION	DATE	APPROVED
-	-	See Sheet1	-	-

IR-FREON-D provides one channel 4-20 milliamp analog output or 2-10VDC analog output . The maximum output impedance is 600 ohms for 4-20mA output. The maximum current is 10 mA for 2-10VDC output.

Test point SIG+ and SIG- are used to measure the current online when the IR-FREON-D is working in the field.

- Jump J5 2-3 : 2-10VDC Output
- Jump J5 1-2 : 4-20mA Output (Default)

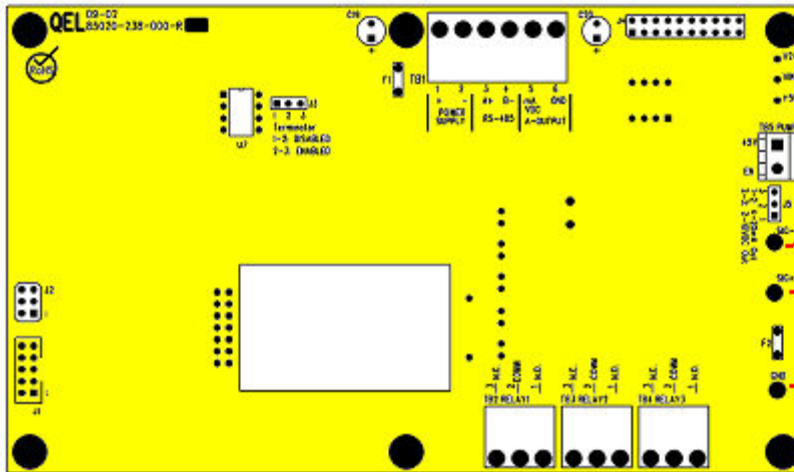

PROPRIETARY AND CONFIDENTIAL
 THE INFORMATION CONTAINED IN THIS DRAWING IS THE SOLE PROPERTY OF <INSERT COMPANY NAME HERE>. ANY REPRODUCTION IN PART OR AS A WHOLE WITHOUT THE WRITTEN PERMISSION OF <INSERT COMPANY NAME HERE> IS PROHIBITED.

		UNLESS OTHERWISE SPECIFIED:		NAME		DATE		Quatrosense Environmental Ltd	
		DIMENSIONS ARE IN INCHES		DRAWN		XY		2009/03/13	
		TOLERANCES:		CHECKED		XY		2009/03/13	
		FRACTIONAL ±		ENG APPR.		XY		2009/03/13	
		ANGULAR: MACH ± BEND ±		MFG APPR.				TITLE: IR-FREON-D INSTALLATION DRAWING	
		TWO PLACE DECIMAL ±		Q.A.					
		THREE PLACE DECIMAL ±		COMMENTS:				SIZE	
		INTERPRET GEOMETRIC TOLERANCING PER:						DWG. NO.	
		MATERIAL						85050-202-000	
		FINISH						REV	
NEXT ASSY		USED ON						B	
APPLICATION		DO NOT SCALE DRAWING						SCALE: 1:2	
								SHEET 4 OF 5	

CONNECTION TO DCS

REVISIONS				
ZONE	REV.	DESCRIPTION	DATE	APPROVED
-	-	See Sheet1	-	-

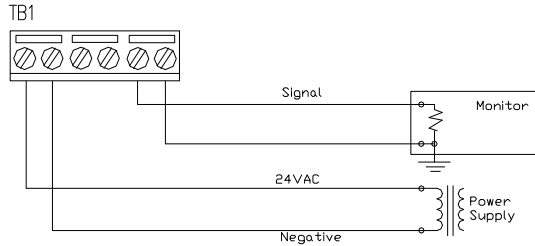

Analog Signal + Floating AC Power Supply

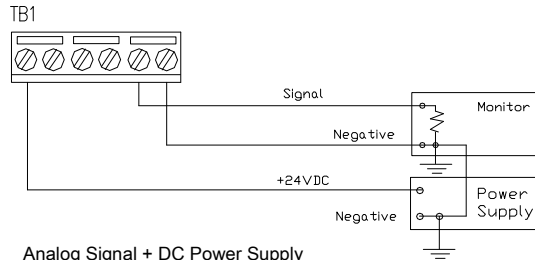

Analog Signal + DC Power Supply

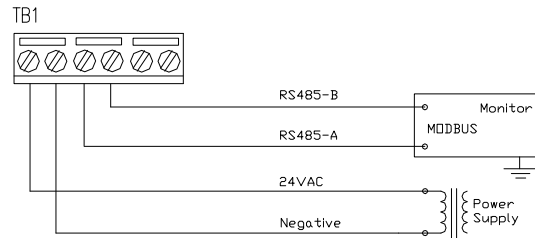

RS485 Digital Signal + Floating AC Power Supply

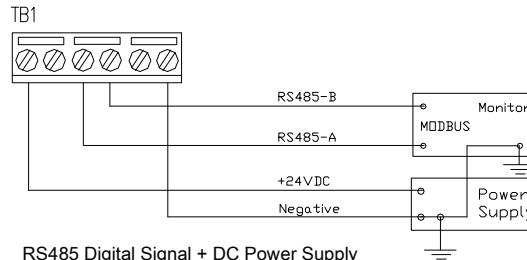

RS485 Digital Signal + DC Power Supply

Application Note:

1. If the device is connected to M-Controller or Q4 Controller, and the power supply is 24VAC, the 24VAC must be a floating AC Power Supply, which means the Negative post of the 24VAC must not be connected to a wire ground referenced to earth. Failure to comply can result in the device damage or other damage.
2. For long distance wiring, choose proper cable to ensure the voltage on each device in nominal range. Lower voltage will expect longer warmup process, and longer time to stabilize.

PROPRIETARY AND CONFIDENTIAL
 THE INFORMATION CONTAINED IN THIS DRAWING IS THE SOLE PROPERTY OF <INSERT COMPANY NAME HERE>. ANY REPRODUCTION IN PART OR AS A WHOLE WITHOUT THE WRITTEN PERMISSION OF <INSERT COMPANY NAME HERE> IS PROHIBITED.

		UNLESS OTHERWISE SPECIFIED:		NAME	DATE	Quatrosense Environmental Ltd TITLE: IR-FREON-D INSTALLATION DRAWING	
		DIMENSIONS ARE IN INCHES		DRAWN	XY		2011/03/11
		TOLERANCES:		CHECKED	XY		2011/03/11
		FRACTIONAL: ±		ENG APPR.	XY		2011/03/11
		ANGULAR: MACH ± BEND ±		MFG APPR.			
		TWO PLACE DECIMAL ±		Q.A.	XY	2011/03/11	
		THREE PLACE DECIMAL ±		COMMENTS:			
		INTERPRET GEOMETRIC TOLERANCING PER:					
		MATERIAL:					
		FINISH:					
NEXT ASSY	USED ON					SIZE B DWG. NO. 85050-202-000 REV B	
APPLICATION		DO NOT SCALE DRAWING				SCALE: 1:2 WEIGHT: SHEET 5 OF 5	